

F2/13T-78ET

70 SUPERLOTUS TOP ELECTRIC FRYERS - TOP

Fryer threephase 13+13 lts - 2 pans cm.
30,5x34x22,5h 2 baskets cm. 28x29x10h - 2
sieves and lids for pan Production: 20 kg/h
(included 1 Head end filler strip mod.TPA-7)



Construction - Fabricated using CrNi 18/10 AISI 304 grade Stainless Steel Scotch-Brite Satin polish Finish, incorporating 2 mm thick worktop, rounded edges, chromed details and rear splash back. Knobs with waterproof grades IPX5. Model - Professional Electric Fryer. With single or Double tank to include both basket and lids, tank filter with basket support. Double Thermostat for operating and over heat safety. Front oil drain. Maintenance - All serviceable parts are accessible by the easy removal of front control panel. Easy tank cleaning by rotating heating element. Fittings - Appliance is supplied with adjustable feet.



ITALIAN CULINARY ART

The pictures are purely representative. The manufacturer reserves the right to modify the technical data and models without previous notice.

F2/13T-78ET

70 SUPERLOTUS TOP
ELECTRIC FRYERS - TOP

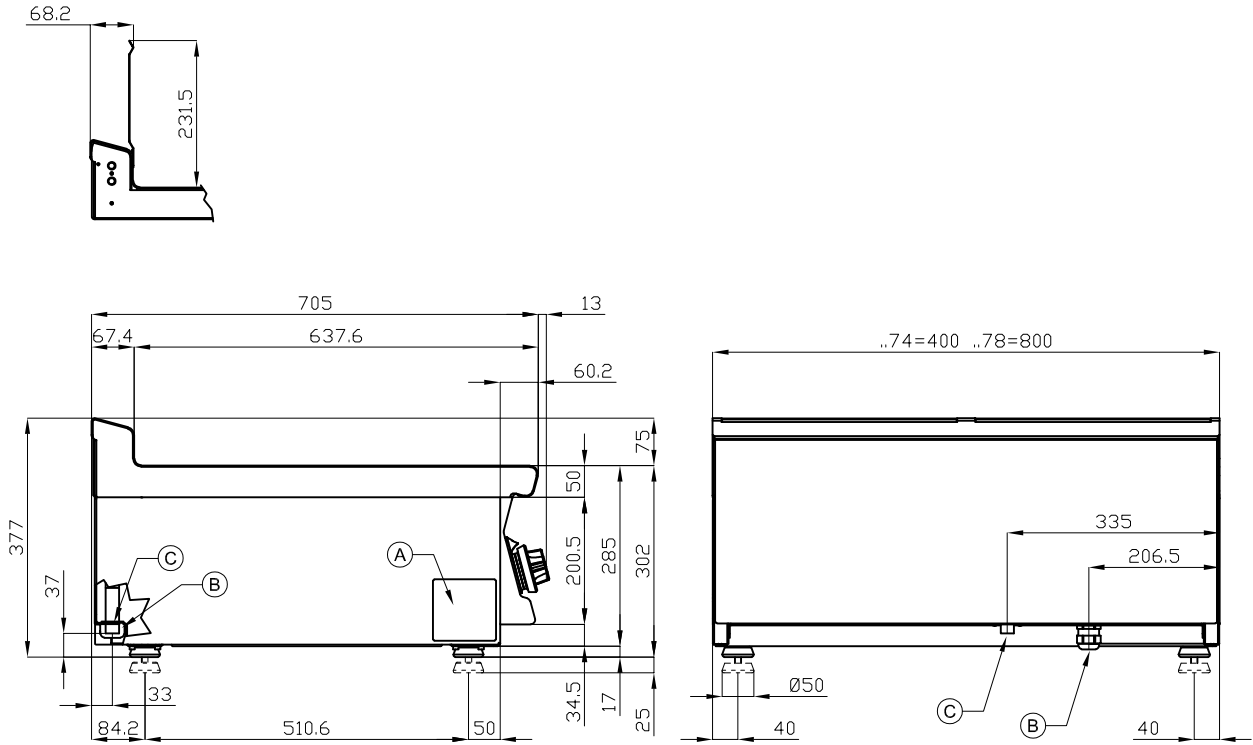

A	Data plate	B	Electrical connection
---	------------	---	-----------------------

MODEL: F2/13T-78ET
 DIMENSIONS: cm. 80x 70,5x 28h
 ELECTRIC POWER: 21,9 kW
 VOLTAGE: 400V~3N
 FREQUENCY: 50/60 Hz



kg: 75
 m³: 0.345
 mm: 830x770x540

BUY LOTUS BUY ITALY

The pictures are purely representative. The manufacturer reserves the right to modify the technical data and models without previous notice.



LOTUS S.P.A. Via Calmaor, 46
 31020 San Vendemiano(TV) - Italy
 Tel. + 39 0438 778020 / 778468
 Fax + 39 0438 778277
 www.lotuscookers.it - lotus@lotuscookers.it